

HannStar Product Specification **(Preliminary)**

4.3” Color TFT-LCD Module

Model : HSD043I9W1-A**

Note:

1. Please contact HannStar Display Corp. before designing your product based on this module specification.
2. The information contained herein is presented merely to indicate the characteristics and performance of our products. No responsibility is assumed by HannStar for any intellectual property claims or other problems that may result from application based on the module described herein.
3. The mark “**” of Model means sub-model code.

Record of Revisions

Rev.	Date	Sub-Model	Description of change
1.0	Nov, 12, 2008	-	Preliminary Product Specification was first released.
1.1	Jan, 13, 2009	-	Pin Assignment Modified: 35 th pin corrected as NC (P11) Electrical Absolute Rating: B/L Unit modified (P5) Electrical Characteristics: B/L Unit modified (P13) Package Specification modified (P22)

Contents

1.0	General description	p.4
2.0	Absolute maximum ratings	p.5
3.0	Optical characteristics	p.6
4.0	Block diagram	p.10
5.0	Interface pin connection	p.11
6.0	Electrical characteristics	p.13
7.0	Reliability test items.....	p.21
8.0	Outline dimension	p.22
9.0	Lot mark	p.23
10.0	Package specification	p.24
11.0	General precaution	p.25

1.0 GENERAL DESCRIPTION

1.1 Introduction

HannStar Display model HSD043I9W1-A is a color active matrix thin film transistor (TFT) liquid crystal display (LCD) that uses amorphous silicon TFT as a switching device. This model is composed of a TFT LCD panel, a driving circuit and a back light system. This TFT LCD has a 4.3 (16:9) inch diagonally measured active display area with WQVGA (480 horizontal by 272 vertical pixel) resolution.

1.2 Features

- 4.3 (16:9 diagonal) inch configuration
- 8-bit color depth with 256 gray-scale
- Parallel 24-bit or serial 8-bit RGB data input
- RoHS and Halogen-Free compliance

1.3 Applications

- Personal Navigation Device
- Multimedia applications and Others AV system

1.4 General information

Item	Specification	Unit	
Outline Dimension	105.5 x 67.2 x 2.9 (Typ.)	mm	
Display area	95.04(H) x 53.856(V)	mm	
Number of Pixel	480 RGB (H) x 272(V)	pixels	
Pixel pitch	0.198(H) x 0.198(V)	mm	
Pixel arrangement	RGB Vertical stripe		
Display mode	Normally white		
Surface treatment	Antiglare, Hard-Coating (3H)		
Weight	(50)(Typ.)	g	
Back-light	LED Side-light type		
Power Consumption	Logic System	(0.09) (Max.)	W
	B/L System	(0.924) (Max.)	W

1.5 Mechanical Information

Item	Min.	Typ.	Max.	Unit	
Module Size	Horizontal(H)	105.2	105.5	105.8	mm
	Vertical(V)	66.9	67.2	67.5	mm
	Depth(D)	—	2.9	3.2	mm
Weight (Without inverter)	—	(43.5)	—	g	

2.0 ABSOLUTE MAXIMUM RATINGS

2.1 Electrical Absolute Rating

2.1.1 TFT LCD Module

Item	Symbol	Min.	Max.	Unit	Note
Power supply voltage	VDD	-0.3	5.0	V	GND=0
Logic Signal Input Level	V _i	-0.3	5.0	V	

2.1.2 Back-Light Unit

Item	Symbol	Typ.	Max.	Unit	Note
LED current	I _L	40	—	mA	(1)(2)(3)
LED voltage	V _L	19.8	—	V	(1)(2)(3)

Note

- (1) Permanent damage may occur to the LCD module if beyond this specification. Functional operation should be restricted to the conditions described under normal operating conditions.
- (2) Ta =25±2°C
- (3) Test Condition: LED current 40 mA. The LED lifetime could be decreased if operating IL is larger than 40mA.

2.2 Environment Absolute Rating

Item	Symbol	Min.	Max.	Unit	Note
Operating Temperature	T _{opa}	-20	70	°C	
Storage Temperature	T _{stg}	-30	80	°C	

3.0 OPTICAL CHARACTERISTICS

3.1 Optical specification

Item		Symbol	Condition	Min.	Typ.	Max.	Unit	Note
Contrast		CR	$\Theta=0$ Normal viewing angle	(480)	(600)	—		(1)(2)
Response time	Rising	T_R		—	(2)	(4)	msec	(1)(3)
	Falling	T_F		—	(6)	(12)		
White luminance (Center)		Y_L		(400)	(500)	—	cd/m ²	(1)(4)(7) ($I_L=40mA$)
Color chromaticity (CIE1931)	White	W_x		(0.260)	(0.310)	(0.360)		(1)(4)
		W_y	(0.280)	(0.330)	(0.380)			
Viewing angle	Hor.	Θ_L	(65)	(75)	—			
		Θ_R	(65)	(75)	—			
	Ver.	Θ_U	(50)	(60)	—			
		Θ_D	(60)	(70)	—			
Brightness uniformity		B_{UNI}	$\Theta=0$	70	—	—	%	(5)(7)
Optima View Direction		6 O' clock						(6)

3.2 Measuring Condition

- Measuring surrounding: dark room
- LED current I_L : 40mA
- Ambient temperature: $25\pm 2^\circ C$
- 15min. warm-up time.

3.3 Measuring Equipment

- FPM520 of Westar Display technologies, INC., which utilized SR-3 for Chromaticity and BM-5A for other optical characteristics.
- Measuring spot size: 20 ~ 21 m

Note (1) Definition of Viewing Angle:

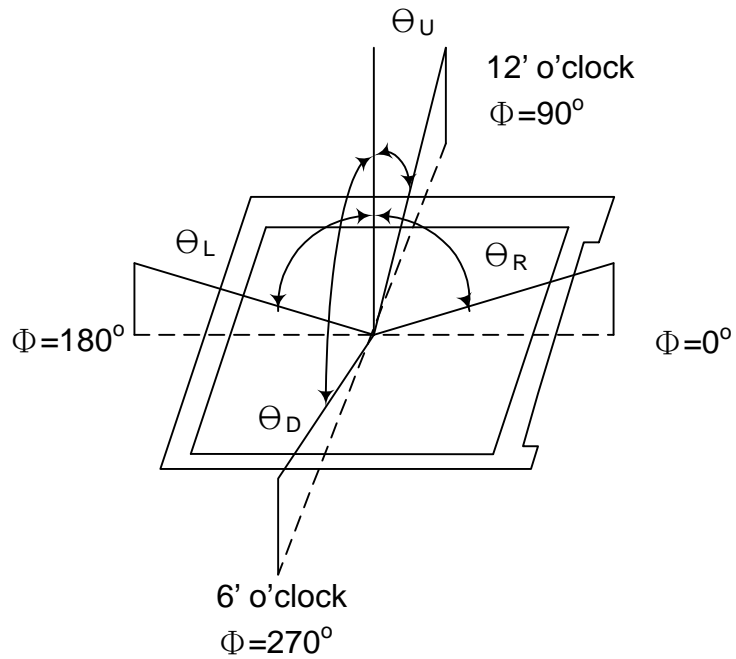

Note (2) Definition of Contrast Ratio (CR):
measured at the center point of panel

$$CR = \frac{\text{Luminance with all pixels white}}{\text{Luminance with all pixels black}}$$

Note (3) Definition of Response Time: Sum of T_R and T_F

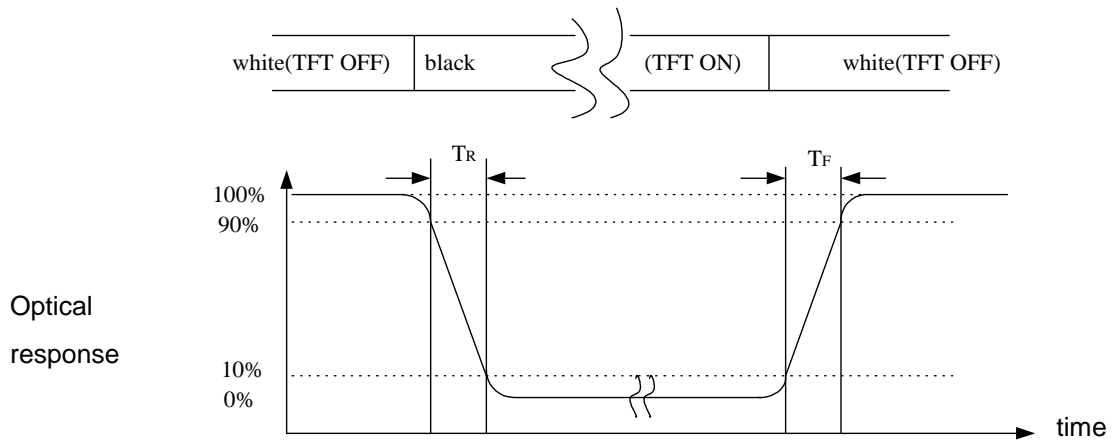

Note (4) Definition of optical measurement setup

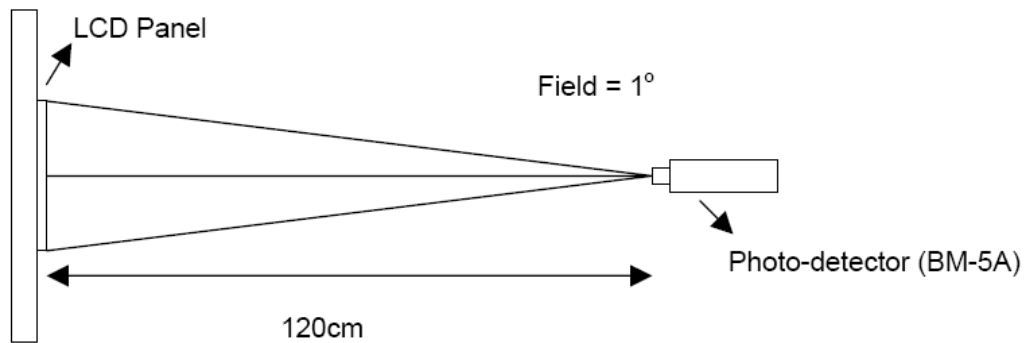

Note (5) Definition of brightness uniformity

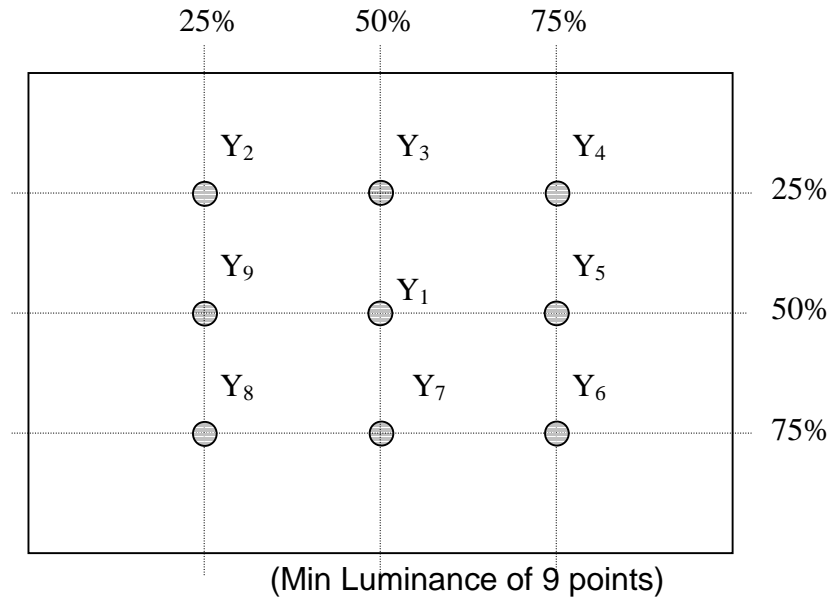

$$\text{Luminance uniformity} = \frac{(\text{Min Luminance of 9 points})}{(\text{Max Luminance of 9 points})} \times 100\%$$

Note (6) Rubbing Direction (The different Rubbing Direction will cause the different optima view direction.)

Note (7) Measured at the brightness of the panel when all terminals of LCD panel are electrically open.

4.0 BLOCK DIAGRAM

4.1 TFT LCD Module

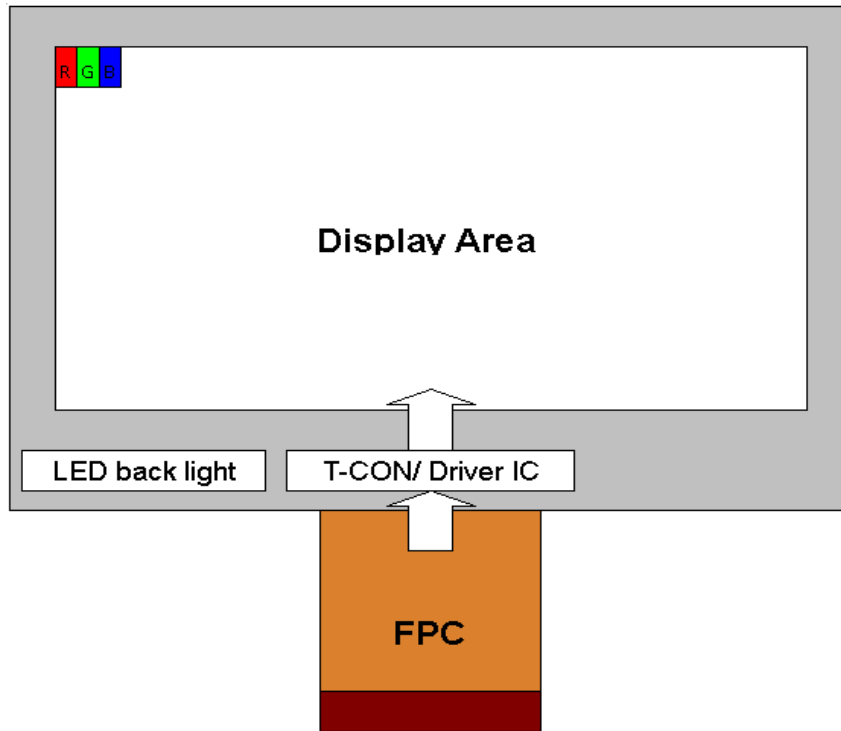

4.2 Pixel Format

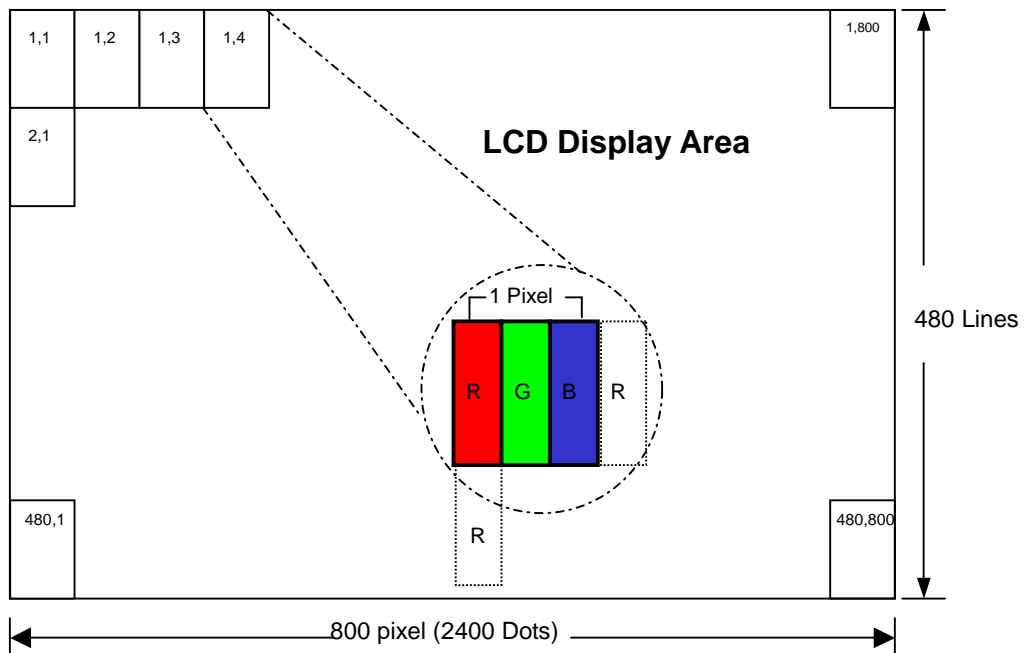

5.0 INPUT INTERFACE PIN ASSIGNMENT

FPC connector is used for electronics interface. The recommended model is FH19SC-40S-0.5SH (05) manufactured by HIROSE.

Pin No	Symbol	I/O	Function
1	V _{LED-}	P	Power for LED backlight cathode
2	V _{LED+}	P	Power for LED backlight anode
3	GND	P	Power ground
4	V _{DD}	P	Power voltage
5	R0	I	Red data (LSB)
6	R1	I	Red data
7	R2	I	Red data
8	R3	I	Red data
9	R4	I	Red data
10	R5	I	Red data
11	R6	I	Red data
12	R7	I	Red data (MSB)
13	G0	I	Green data (LSB)
14	G1	I	Green data
15	G2	I	Green data
16	G3	I	Green data
17	G4	I	Green data
18	G5	I	Green data
19	G6	I	Green data
20	G7	I	Green data (MSB)
21	B0	I	Blue data (LSB)
22	B1	I	Blue data
23	B2	I	Blue data
24	B3	I	Blue data
25	B4	I	Blue data
26	B5	I	Blue data
27	B6	I	Blue data
28	B7	I	Blue data (MSB)
29	GND	P	Power ground
30	DCLK	I	Pixel clock
31	DISP	I	Display on/ off
32	HSYNC	I	Horizontal sync signal
33	VSYNC	I	Vertical sync signal
34	DE	I	Data enable
35	NC	-	No connect
36	GND	P	Power ground
37	X_R	I/O	Right electrode - differential analog
38	Y_B	I/O	Bottom electrode - differential analog
39	X_L	I/O	Left electrode - differential analog
40	Y_T	I/O	Top electrode - differential analog

I/O: I: input, O: output, P: power

6.0 ELECTRICAL CHARACTERISTICS

6.1 DC Electrical Characteristics

Parameters	Symbol	Min.	Typ.	Max.	Unit	Note
Supply voltage	V_{DD}	3.0	3.3	3.6	V	
Input signal voltage	V_{iH}	$0.7 V_{DD}$	-	V_{DD}	V	Note (1)
	V_{iL}	GND	-	$0.3 V_{DD}$	V	Note (1)
Current of power supply	I_{DD}	-	(TBD)	-	mA	$V_{DD} = 3.3V$

Note (1): HSYNC, VSYNC, DE, R/G/B Data

Note (2): GND = 0V

6.2 Back-Light Unit

The backlight system is an edge-lighting type with 12 LED.

The characteristics of the LED are shown in the following tables.

Parameters	Symbol	Min.	Typ.	Max.	Unit	Note
LED current	I_L	—	40	—	mA	(2)
LED voltage	V_L	—	19.8	—	V	
LED life time	Hr	10000	—	—	Hour	(1)(2)

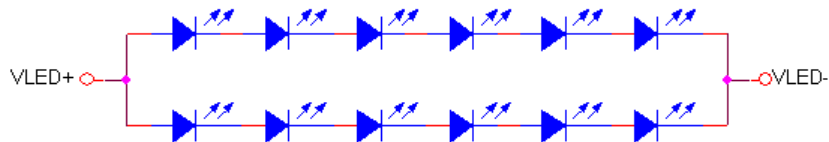

LED Light Bar Circuit

Note (1) LED life time (Hr) can be defined as the time in which it continues to operate under the condition: $T_a=25\pm3\text{ }^\circ\text{C}$, typical I_L value indicated in the above table until the brightness becomes less than 50%.

Note (2) The “LED life time” is defined as the module brightness decrease to 50% original brightness at $T_a=25\text{ }^\circ\text{C}$ and $I_L=40\text{mA}$. The LED lifetime could be decreased if operating I_L is larger than 40mA. The constant current driving method is suggested.

Note (3) Suggested schematic of LED backlight driver.

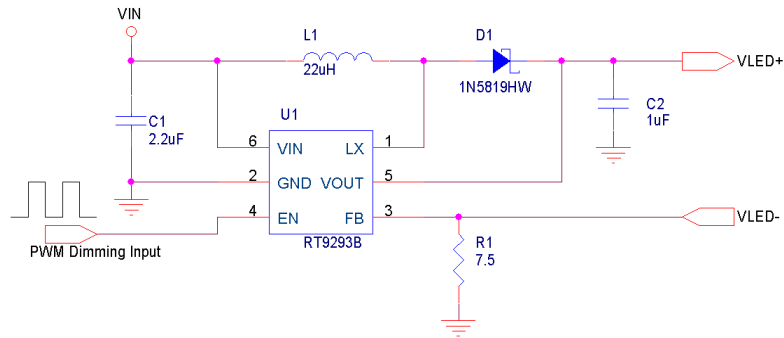

6.3 Data Input Format

Parallel 24-bit RGB Input Timing Table

Parameters	Symbol	Min.	Typ.	Max.	Unit	Conditions
DCLK frequency	fclk	5	9	12	MHz	
VSYNC period time	Tv	277	288	400	Th	
VSYNC display area	Tvd	272			Th	
VSYNC back porch	Tvbp	3	8	31	Th	
VSYNC front porch	Tvfp	2	8	93	Th	
HSYNC period time	Th	520	525	800	DCLK	
HSYNC display area	Thd	480			DCLK	
HSYNC back porch	Thbp	36	40	255	DCLK	
HSYNC front porch	Thfp	4	5	65	DCLK	

Serial 8-bit RGB Input Timing Table

Parameters	Symbol	Min.	Typ.	Max.	Unit	Conditions
DCLK frequency	fclk	24	27	30	MHz	
VSYNC period time	Tv	277	288	400	Th	
VSYNC display area	Tvd	272			Th	
VSYNC back porch	Tvbp	3	8	31	Th	
VSYNC front porch	Tvfp	2	8	93	Th	
HSYNC period time	Th	1560	1716	1900	DCLK	
HSYNC display area	Thd	1440			DCLK	
HSYNC back porch	Thbp	108	120	255	DCLK	
HSYNC front porch	Thfp	12	168	205	DCLK	

Vertical Input Timing

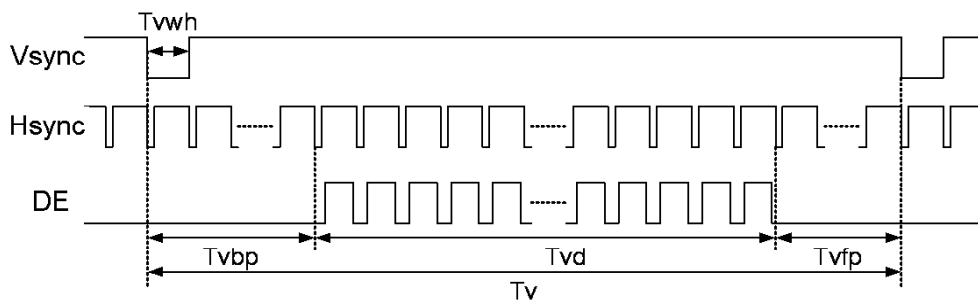

Parallel 24-bit RGB Mode Data Format

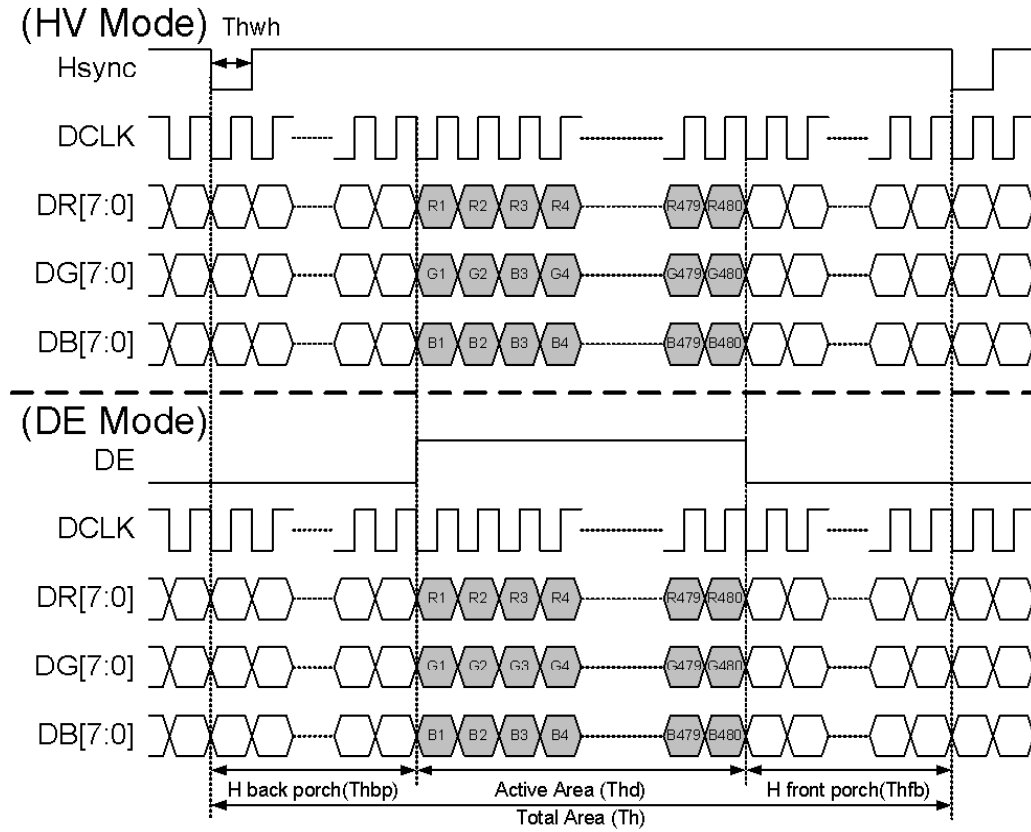

Serial 8-bit RGB Mode Data Format

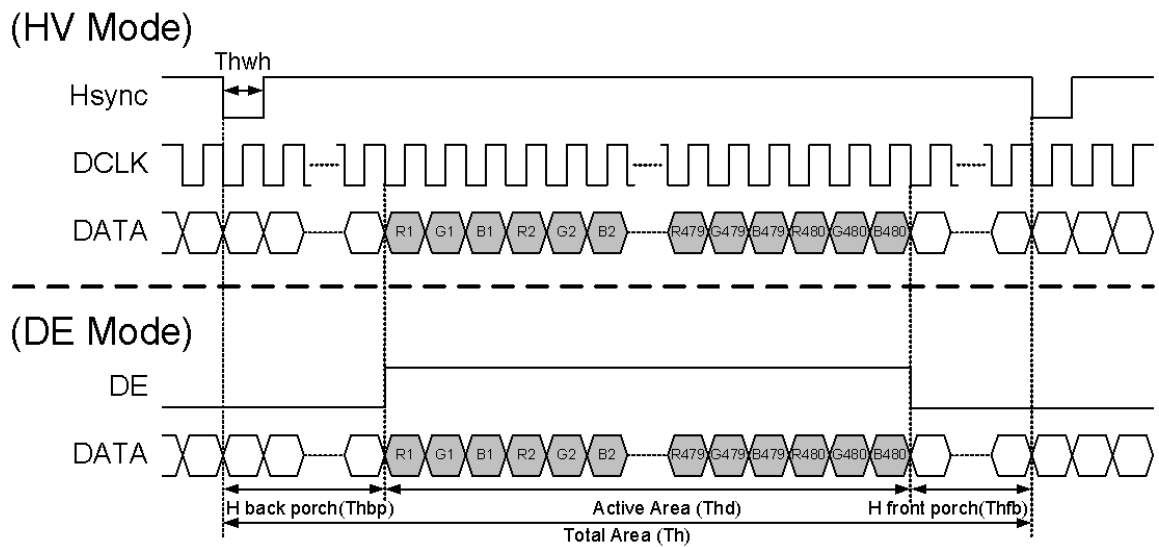

6.4 AC Electrical Characteristics

Parameters	Symbol	Min.	Typ.	Max.	Unit	Conditions
DCLK period time	Tclk	83.3	111.1	200	ns	Parallel 24-bit RGB mode
		33.3	37.0	41.7	ns	Serial 8-bit RGB mode
DCLK rising time	Trck	-	-	9	ns	
DCLK falling time	Tfck	-	-	9	ns	
DCLK pulse duty	Tcwh	40	50	60	%	
DE setup time	Tdesu	12	-	-	ns	
DE hold time	Tdehd	12	-	-	ns	
HSYNC pulse width	Thwh	1	-	-	DCLK	
HSYNC setup time	Thsu	12	-	-	ns	
HSYNC hold time	Thhd	12	-	-	ns	
VSYNC pulse width	Tvwh	1	-	-	Th	
VSYNC setup time	Tvsu	12	-	-	ns	
VSYNC hold time	Tvhd	12	-	-	ns	
Data setup time	Tdsu	12	-	-	ns	
Data hold time	Tdhd	12	-	-	ns	

Clock and Data Input Timing Diagram

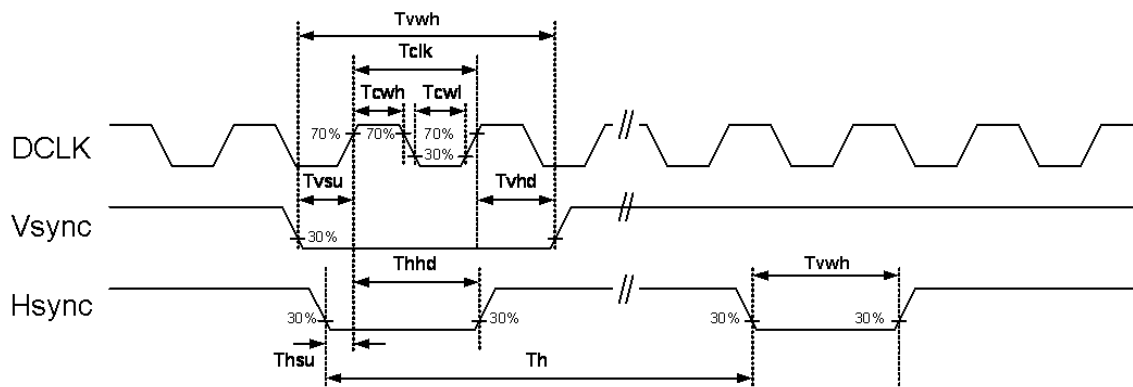
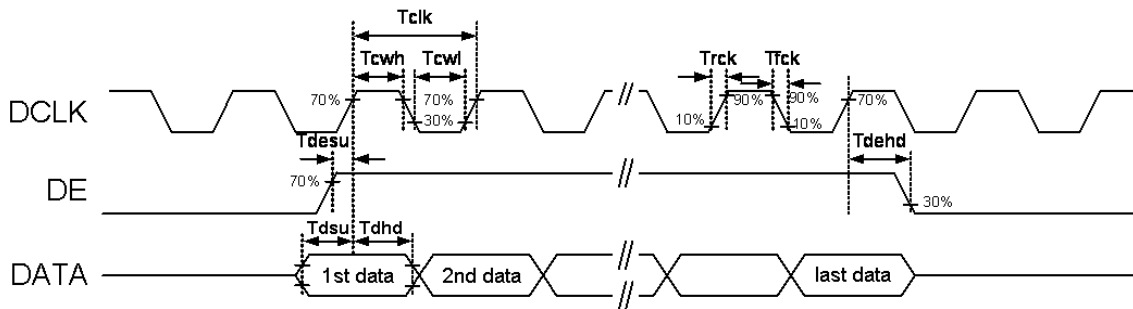

6.5 Power On/Off Sequence

Power On Sequence

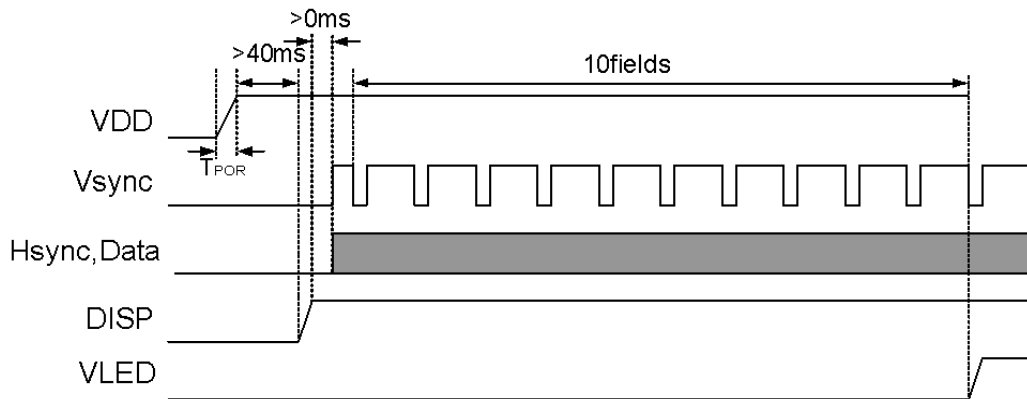

Power Off Sequence

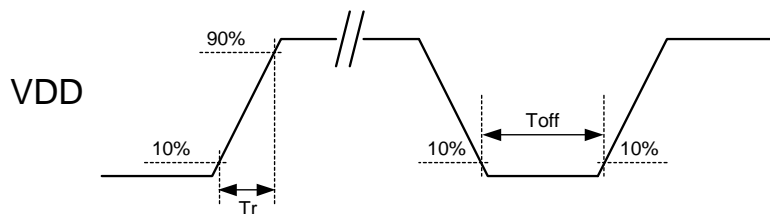
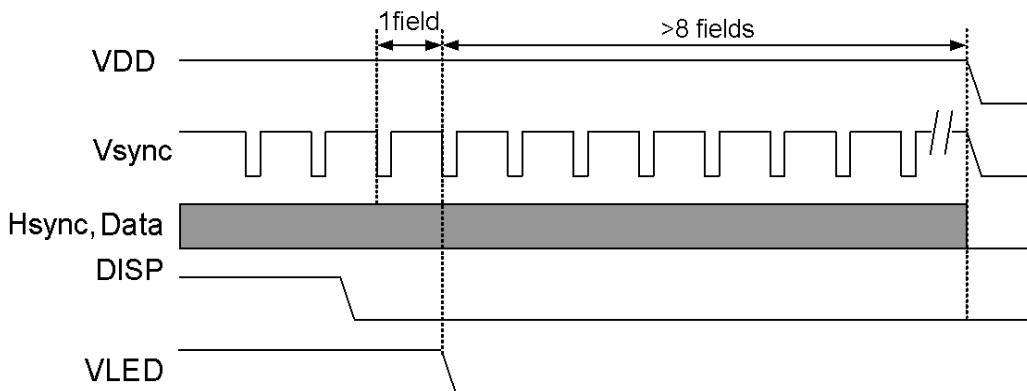

VDD power input timing

Notes:

- Data include R0~R7, G0~G7, B0~B7, HSD, VSD, DCLK, DE
- Power on sequence: VDD → DISP → Data → V_{LED}
- Power off sequence: DISP → V_{LED} → Data → VDD
- VDD power input timing: $0.5ms < T_r < 10ms$; $T_{off} > 500ms$

7.0 Reliability test items

No.	Item	Conditions	Remark
1	High Temperature Storage	Ta=+80°C, 240hrs	
2	Low Temperature Storage	Ta=-30°C, 240hrs	
3	High Temperature Operation	Ta=+70°C, 240hrs	
4	Low Temperature Operation	Ta=-20°C, 240hrs	
5	High Temperature and High Humidity (operation)	Ta=+60°C, 90%RH, 240hrs	
6	Thermal Cycling Test (non operation)	-30°C(30min) → +80°C(30min), 200cycles	
7	Electrostatic Discharge	±200V,200pF(0Ω) 1 time/each terminal	
8	Vibration	1.Random: 1.04Grms, 5~500Hz, X/Y/Z, 30min/each direction 2. Sine: Freq. Range: 8~33.3Hz Stoke: 1.3mm Sweep: 2.9G, 33.3~400Hz X/Z: 2hr, Y: 4hr, cyc: 15min	
9	Shock	100G, 6ms, ±X, ±Y, ±Z 3 time for each direction	JIS C7021, A-10 (Condition A)
10	Vibration (with carton)	Random: 0.015G ² /Hz, 5~200Hz -6dB/Octave, 200~400Hz XYZ each direction: 2hr	
11	Drop (with carton)	Height: 60cm 1 corner, 3 edges, 6 surfaces	JIS Z0202

Note: There is no display function NG issue occurred, all the cosmetic specification is judged before the reliability stress.

8.0 OUTLINE DIMENSION

8.1 Outline Dimension

Unit: mm

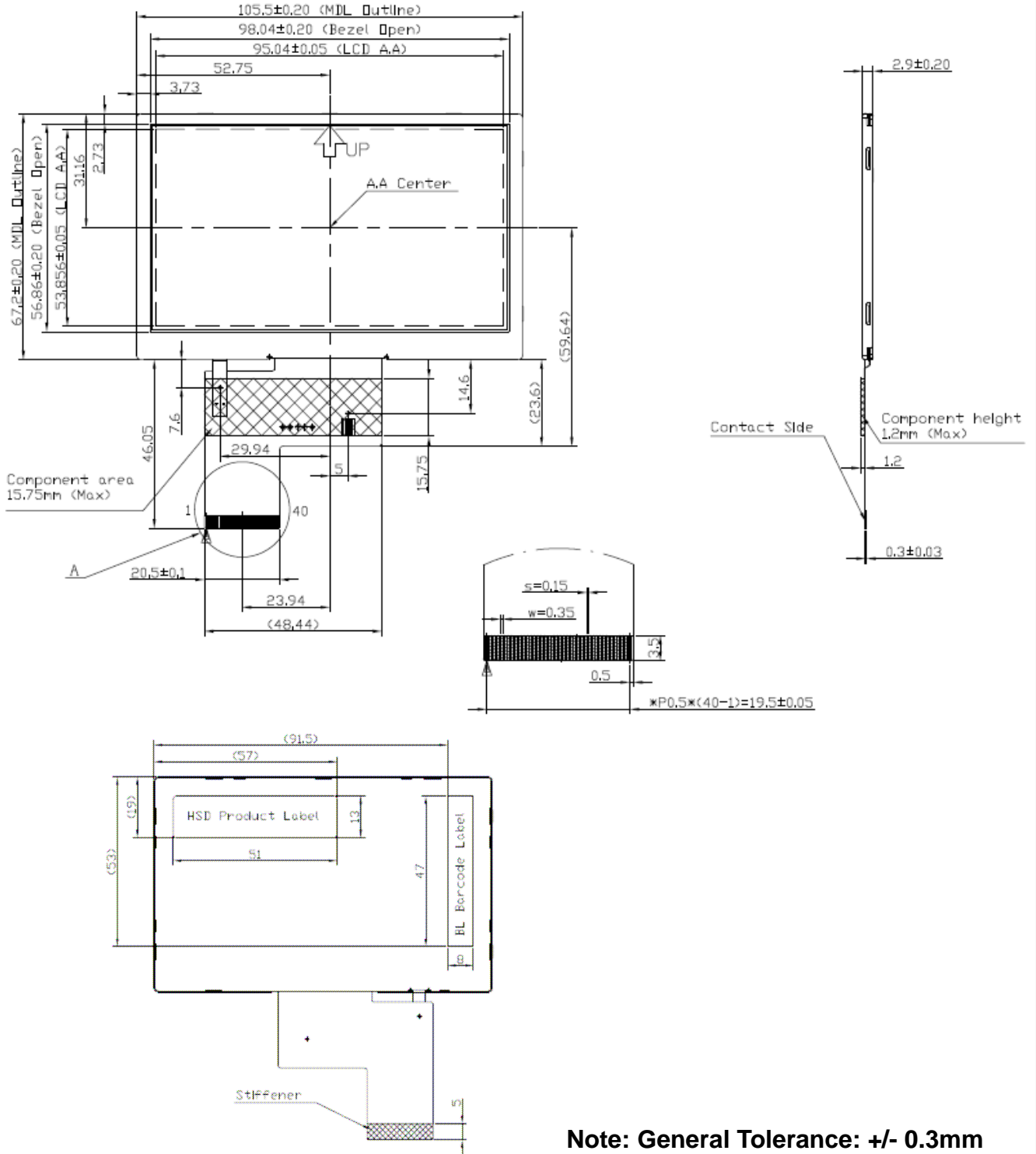

Note: General Tolerance: +/- 0.3mm

